



# ENVICE Food Waste Processor

The special 1% will change the world.



# E5A-05K

5kg Compact size,  
Smart space utilization

(Small restaurant / Convenience store etc.)



## Product characteristic

Product name	ENVICE Commercial food waste processor (5kg)
Model name	E5A - 05K
Supply type	Commercial
Color	Silver
Product size	(W)380x(D)670x(H)750 mm
Weight / Packing weight	93kg/103kg
Rate voltage	AC 220V/50HZ (Single phase) - Customization by country
Maximum consumption power	1.3kw/h
Processing method/ Processing Time	Dry grinding / About 6 hours
Installation location	Indoor / Outdoor



- Environment-friendly**  
 Leakage rate during processing 0%(Only condensate drainage)
- The loss rate**  
 About 85% or less
- Moisture content of residue**  
 About 5% or less
- Processing capacity**  
 Various bones, shellfish, tec
- Driving noise**  
 55dB or less
- Consumption power**  
 1kw of power consumed during 1kg processing
- Safety**  
 Equipped with an overload and over temperature detector with the automatic response sensor
- Hygiene**  
 High-temperature sterilization function (About 130°C)
- Convenience**  
 Collect in sawdust or coffee form
- Deodorization method**  
 Air-cooled condensation filtering

# E5A-15K

15kg Exquisite and powerful grinding capacity,  
Smart handling of consumer mistakes

(Small and medium businesses, Motel, Convenience store)

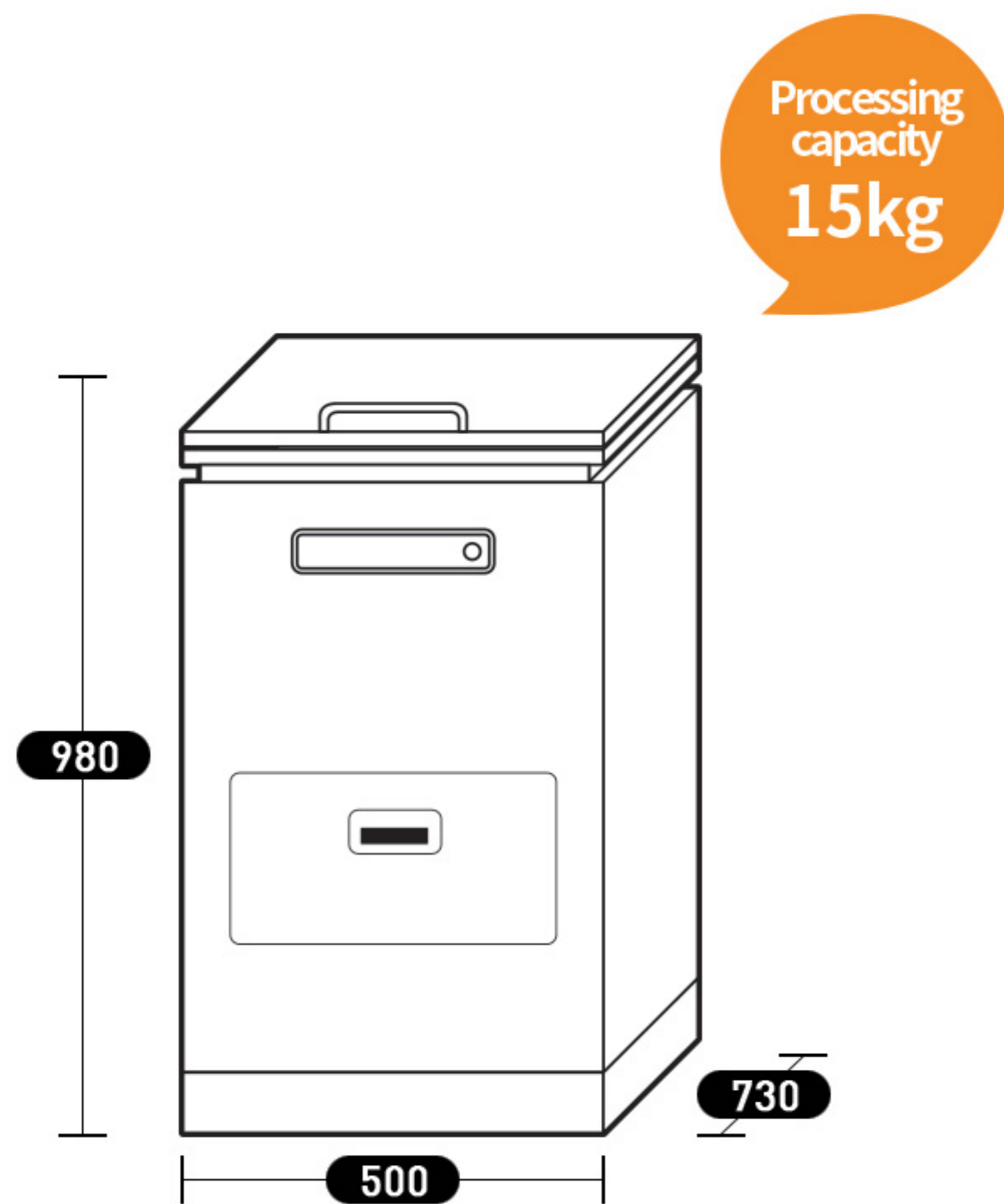

## Product characteristic

Product name	ENVICE Commercial food waste processor (15kg)
Model name	E5A - 15K
Supply type	Commercial
Color	Silver
Product size	(W)500x(D)730x(H)980 mm
Weight / Packing weight	140kg/150kg
Rate voltage	AC 220V/50HZ (Single phase) - Customization by country
Maximum consumption power	2.2kw/h
Processing method/ Processing Time	Dry grinding / About 8 hours
Installation location	Indoor / Outdoor



# E5A-30K

30kg One touch from start to discharge  
Smart use and processing

(Restaurant, Wholesale mart, Fish farm)

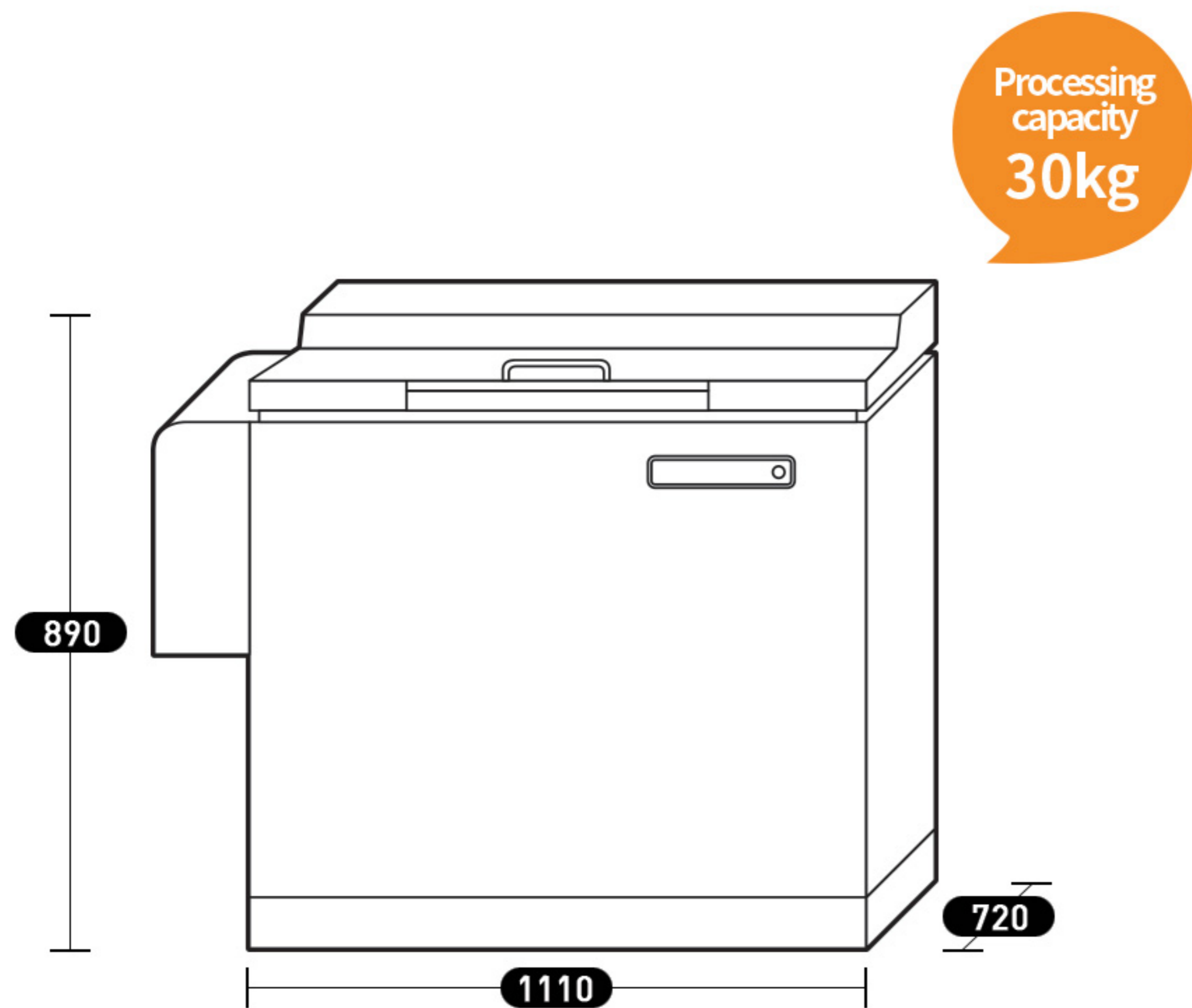

## Product characteristic

Product name	ENVICE Commercial food waste processor (30kg)
Model name	E5A-30K
Supply type	Commercial
Color	Silver
Product size	(W)1,110x(D)720x(H)890 mm
Weight / Packing weight	256kg/276kg
Rate voltage	AC 220V/50HZ (Single phase) - Customization by country
Maximum consumption power	4kw/h
Processing method/ Processing Time	Dry grinding / About 10 hours
Installation location	Indoor / Outdoor



# E5A-50K

50kg Smart processing time/Treatment/Loss rate/  
Moisture content of residue

(Restaurant, Wholesale mart, Fish farm)

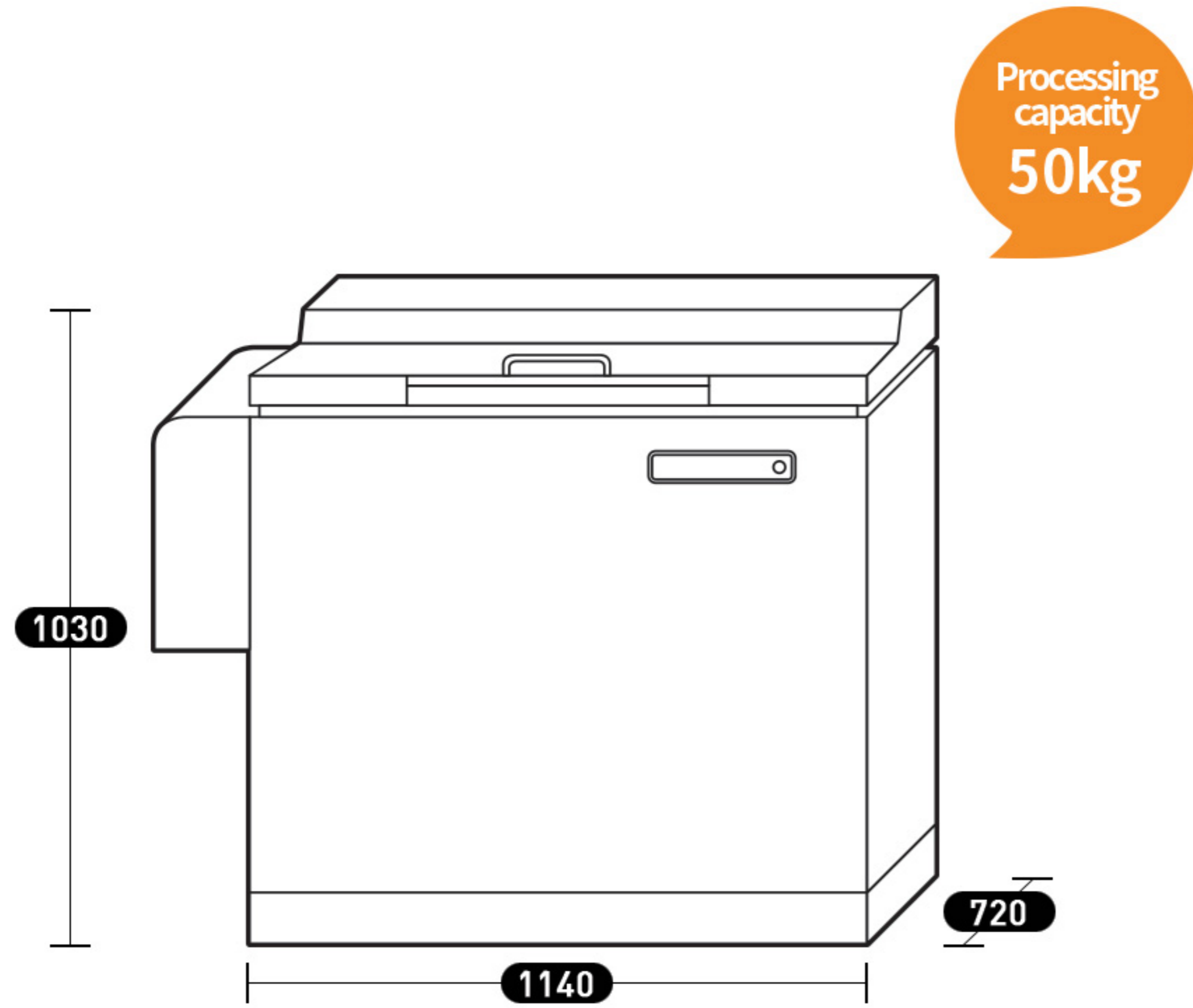

## Product characteristic

Product name	ENVICE Commercial food waste processor (50kg)
Model name	E5A - 50K
Supply type	Commercial
Color	Silver
Product size	(W)1,140x(D)720x(H)1,030 mm
Weight / Packing weight	291kg/311kg
Rate voltage	AC 220V/50HZ (Single phase) - Customization by country
Maximum consumption power	4kw/h
Processing method/ Processing Time	Dry grinding / About 12 hours
Installation location	Indoor / Outdoor



# E5A-99K

99kg Various products by capacity,  
Convenient use and service

(Large food court, Hotel, Wholesale mart, Fish farm)

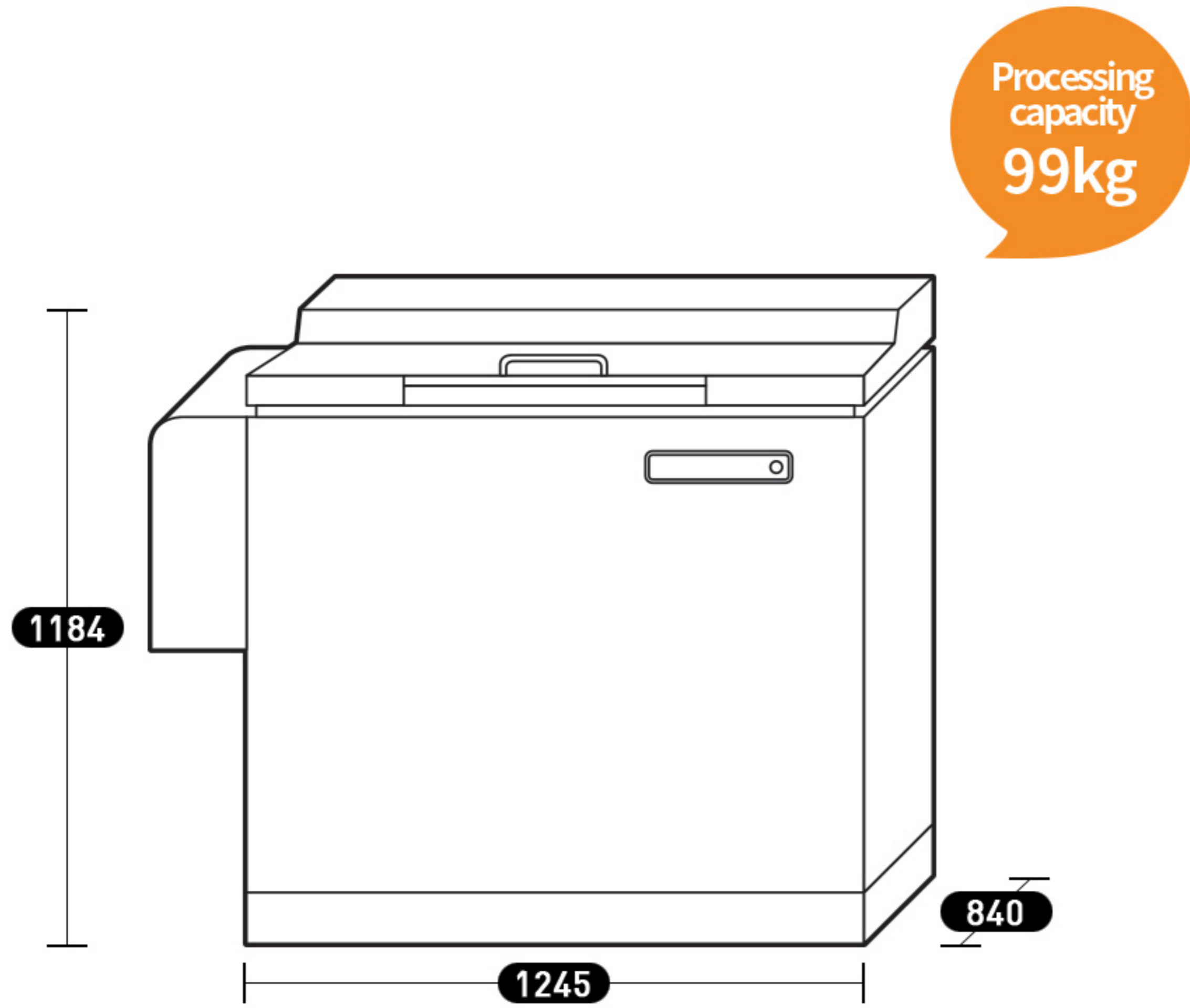

## Product characteristic

Product name	ENVICE Commercial food waste processor (99kg)
Model name	E5A - 99K
Supply type	Commercial
Color	Silver
Product size	(W)1,245x(D)840x(H)1,184 mm
Weight / Packing weight	452kg/472kg
Rate voltage	AC 220V/50HZ (Single phase) - Customization by country
Maximum consumption power	7.8kw/h
Processing method/ Processing Time	Dry grinding / About 14 hours
Installation location	Indoor / Outdoor



# Excellence of ENVICE processing system



## Grinding drying system

**Moisture content of residue**  
(About 5% or less)

**The loss rate**  
(About 85%)

**Ability to process**  
(Hard substances such as nuts)

**Processing time**  
(About 6 hours)

<b>B company</b> Extermination system	<b>W company</b> Dry grinding system	<b>L company</b> Hot air drying system	<b>G company</b> Dehydration-cutting drying system
<p>The loss rate more than 90%</p> <p>Unable to put in hard substances such as nuts</p> <p>Continuous bacterial injection (Heavy maintenance)</p> <p>Processing time 20 hours or more</p>	<p>Dry grinding 5% or less</p> <p>The loss rate 80% or more</p> <p>Processing time 3 or 4 hours</p>	<p>Moisture content of residue (About 10% or more)</p> <p>The loss rate 50% or more</p> <p>Processing time 8 hours or more</p>	<p>Moisture content of residue (About 10% or more)</p> <p>The loss rate 80% or less</p> <p>Unable to put in hard substances such as nuts</p> <p>Processing time 4 hours</p>

## Delivery performance

<b>Household</b>	<p>Japan GND(2,200)/Switzerland VRS(200)/Taiwan VISTA(30)</p> <p>Daelim Hwanghak-dong (263) / Hyundai emco Shincheon-dong(741) / Halla Vivaldi Cheongju (1,400) / Daewoo purgio (800)</p> <p>Lotter castle Samsung-dong (447) / Hanshin Daelimdong(46) / Samsung laemian Zhangan-dong (123) / Daewoo Trump II Yeouido(127)</p> <p>Hyperion Mokdong (152) / Daelim Bangbae (62)</p> <p>Apartments and general housing in the Seoul metropolitan area (4,500)</p>
<b>Commercial</b>	<p>Sushi hongsam(15kg) / Maider hotel (5kg) / mirae convertion (99kg) / funkid kindergarten(10kg) / Hotel Shangri-la (50kg)</p> <p>Pramis(10kg) / Bomim co.,ltd.(30kg) / Shin je-il (50kg) / Hotel &amp; Resort Jeju(50kg) / Oslo(30kg) / Black sands(5kg) / Jeju in hotel (30kg)</p> <p>Aijin(15kg) / Global house(15kg) / Rich hotel(5kg) / Haeoreum kindergarten(30kg) / Gwangjang garden(50kg) / Awol stay hotel(15kg)</p> <p>Haguibaglebagle(15kg) / Hanryu co.,ltd.(50kg) / milbacs(50kg) / Halla kindergarten(30kg) / lusco(30kg) / chamchidaega (15kg)</p> <p>Udo middle school(30kg) / Gangjeong Elementary school(50kg) / Hanuland(30kg) / Moise hajangguk nohyeong branch (50kg)</p> <p>Hanaro market(99kg) / Jaydream(15kg) / Pungkeongchae(5kg) / Swanji resort(5kg) / Jangmi kindergarten(30kg) / Yegrina(5kg)</p> <p>Olti &amp; G (30kg) / Seobu sanatorium(10kg) / Deokrim Jeju Shangri-la(50kg) / Jinmimyeonga(15kg) / 3 black pig brothers(15kg)</p> <p>Haemaru(30kg) / Tira hotel(15kg) / Cocomong eco park(99kg) / Junglim(99kg) / Jeju palace(30kg) / Yongsan youth hostel(30kg)</p> <p>Donirang(50kg) / Sillawon(99kg) / Insung kindergarten(15kg) / Palm valley resort (5kg) / Beautiful resort(5kg) / Backpackers home(5kg)</p> <p>Pareb hotel(99kg) / Haesung parktel(15kg) / Kennystory(30kg) / Namia(30kg) / Bayhill(15kg) / Ocean tree(15kg) / Seri(5kg) / Grandville(5kg)</p> <p>Gasantobang(10kg) / Jungmun stay(10kg) / Grandmer(30kg) / Healthcare town(99kg) / Marine port(5kg) / Taeheung resort(5kg)</p> <p>Samwonyangman(5kg) / Busan bokjip(30kg) / Dongseo industry(5kg) / Sangji shipping(5kg - 4ea) / Dongshan church (99kg - 2ea)</p>



A/S Center  
**82-1644-9022**

The name of ENVICE was combined En in Enforce and Vice in Service, which means we will fulfill customer satisfaction management(B/S+5P+A/S) with our best customer service.

**Head office in Seoul**

4 Floor, 7-7, Baumoe-ro 27-gil, Seocho-gu, Seoul, Republic of Korea  
Tel) 82-2-578-6543 / Fax) 82-2-579-2647

**Factory in Yongin**

205-5, Sinnam-ro, Namyang-eup, Hwaseong-si, Gyeonggi-do, Republic of Korea  
Tel) 82-31-321-9309 / Fax) 82-31-321-9311

ENVICE is a specialized company that produces and sells furniture and food waste processors based on total quality management, pursuing convenience and happiness of life.



Certificate of K mark



Certificate of factory registration



Research institute certificate



Certificate of standards of Private sectors



Certificate of trademark registration



Certificate of trademark registration



Certificate of Trademark Registration



Certificate of trademark registration



Certificate of service mark registration



Certificate of service mark Registration



Electrical appliances safety certificate



Certificate of product



ISO License



ISO License



The design/price of the products in this section may be changed for aesthetic and performance improvement, and the print color may differ from the actual color.  
Some of the parts in the printed material are not handled by our company  
The warranty period for ENVICE products is one year from the date of purchase,  
and the compensation for exchange and refund damages is in accordance with the Ministry of Finance and Economy's Notice on Consumer Damage Compensation.